

# REQUIRED VENTILATION RATE FOR IH ELECTRIC COOKING HEATER IN HOME KITCHENS

Shin-ichi Akabayashi<sup>1†</sup>, and Jun Sakaguchi<sup>2</sup>

<sup>1</sup> Division of Science and Technology, Graduate school of Niigata University, Niigata, Japan

<sup>2</sup> Department of Human Life and Environmental Science, Niigata Women' College, Niigata, Japan

## ABSTRACT

Houses which use only electricity are becoming popular in Japan. Electromagnetic ranges (IH range) are used in those houses. The updraft above an IH range is slower than a gas range. The required ventilation rate is different for a gas range and an IH range. In this study, measurements of updraft velocity and temperature distribution above the IH ranges are conducted. The required ventilation rate for the home kitchen with IH ranges are proposed by this study.

Results are as follows: The position of the maximum air flow velocity, when one range is operated, is directly above the range, and when two ranges are operated, it is in the center of the two ranges. The updraft air flow rate is strongly influenced by the number of ranges. The capture ratio has few differences pertaining to power value of a range. When the number of ranges increases, the capture ratio is small. When two ranges are operated and the capture ratio is 80%, the required ventilation rate is about 150m<sup>3</sup>/h.

## KEYWORDS

IH Cooking heater, Home kitchen, Updraft, Capture ratio, Required ventilation rate

## INTRODUCTION

Houses which use only electricity are becoming popular in Japan. Electromagnetic ranges (IH range) are used in those houses. An IH range has no flames, so there is no combustion gas. Because there is no hot section of a flame, the updraft on an IH range is slower than a gas range. The required ventilation rate is different between a gas range and an IH range. But Japan has no guidelines or regulations of the required ventilation rate for an IH range at present. Ventilation rate is decided by the required ventilation rate of the electric heater. The required ventilation rate of an electric heater type range is determined by the air flow rate of updraft above the range. According to previous research, it is known that air flow rate of updraft is proportional to the power of a range.

In this study, measurements of updraft velocity and temperature distribution above IH ranges are conducted. The required ventilation rate for a home kitchen with IH ranges is proposed.

## OUTLINE OF EXPERIMENT

Fig.1 shows the specifications of the IH range. The hood has a simple shape and the size is 600mm [width] x 600mm [depth] x 600mm [height]. The capture ratio of the hood is influenced by indoor air flow, so a wall was set around the measurement space.

### Experimental Conditions

Table 1 and Table 2 show experimental conditions of the updraft air flow rate. Fig. 2 shows the measuring plane of updraft velocity, Fig. 3 shows detail of the experimental conditions. Air flow

† Corresponding Author: Tel: +81 25 262 7266, Fax: +81 25 262 7188

E-mail address: akabayas@cc.niigata-u.ac.jp

velocities were measured by velocity, direction and temperature at intervals of 50mm using a 3-dimensional ultrasonic anemometers and a thermocouple.

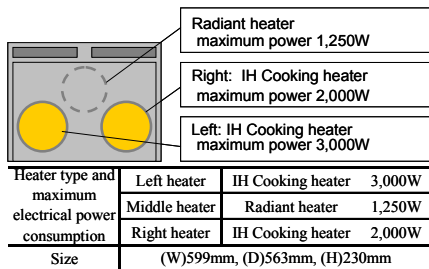

Figure 1. Specification of IH ranges

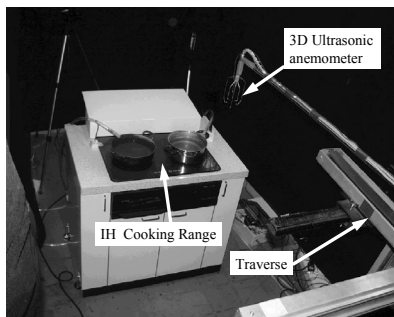
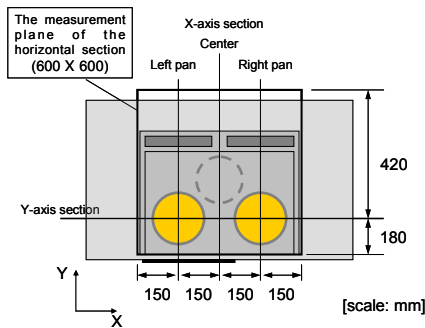
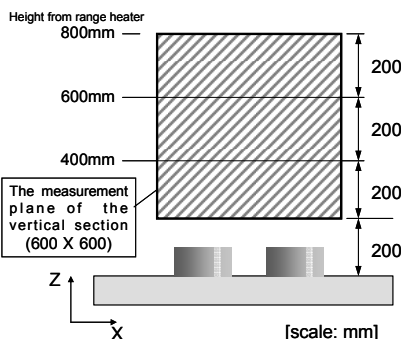

Figure 3. Detail of experimental conditions



(1) Z-axis section



(2) Y-axis section

Figure 2. Measuring plane of updraft velocity

Table 1. Experimental conditions of the updraft air flow rate (horizontal section)

Height from heating surface	Range conditions	Exhaust air flow rate
800mm	2 range (2kW+2kW)	Without range hood 100 m <sup>3</sup> /h 200 m <sup>3</sup> /h 300 m <sup>3</sup> /h
	1 range (left 2kW)	
	1 range (left 1kW)	
600mm	2 range (2kW+2kW)	
	1 range (left 2kW)	
	1 range (left 1kW)	
400mm	2 range (2kW+2kW)	
	1 range (left 2kW)	
	1 range (left 1kW)	

Table 2. Experimental conditions of the updraft air flow rate (vertical section)

Range	Range condition	Section	
One range	Left 2kW	X-axis section/ Top of Left pan	
		Y-axis section	
	Right 1kW	X-axis section/ Top of Right pan	
Two ranges	Left 0.5kW	Y-axis section	
		Right 2kW + Left 2kW	X-axis section/ Top of Left pan
			X-axis section/ Top of Right pan
	Right 1kW + Left 2kW	X-axis section/ Center	
		Y-axis section	
		Right 1kW + Left 1kW	X-axis section/ Top of the Left
X-axis section/ Top of Right pan			
X-axis section/ Center			
		Y-axis section	

## Capture ratio

Table 3 shows the experimental conditions of the capture ratio. Fig. 4 shows the outline of the experiment. Ethylene gas ( $C_2H_4$ ), which is used as a tracer gas, is generated from the edge of the pan. The concentration at a point inside the hood was measured by FID. The capture ratio was calculated by formula [1]. The emission rate of the full capture ratio was calculated by the exhaust air flow rate and the ethylene concentration of exhaust air when the tracer gas was supplied from inside the hood. The exhaust air flow rate was determined by a JIS standard orifice. The exhaust air flow rate was controlled by the inverter. In this study, there was a wall at the back of the range to reproduce common home use. In consideration that there may be a spread tracer gas in the room, the test room was ventilated.

$$\text{Capture Rate} = \frac{\text{Exhaust Air } C_2H_4 \text{ Concentration} - \text{Indoor Air } C_2H_4 \text{ Concentration}}{\text{Emission Rate of Full Capture Rate}} \times \text{Exhaust Air Volume} \times 100(\%) \dots\dots [1]$$

Table 3. Experimental conditions of capture ratio

The height of the lower edge of the hood	Range condition	Exhaust air flow rate
800mm	Right 2kW + Left 2kW	50m <sup>3</sup> /h
	Right 1kW + Left 2kW	
	Right 1kW + Left 1kW	
	Left 2kW	
600mm	Left 1kW	100m <sup>3</sup> /h
	Right 2kW + Left 2kW	150m <sup>3</sup> /h
	Right 1kW + Left 2kW	200m <sup>3</sup> /h
	Right 1kW + Left 1kW	250m <sup>3</sup> /h
400mm	Left 2kW	300m <sup>3</sup> /h
	Left 1kW	
	Right 2kW + Left 2kW	
	Right 1kW + Left 1kW	

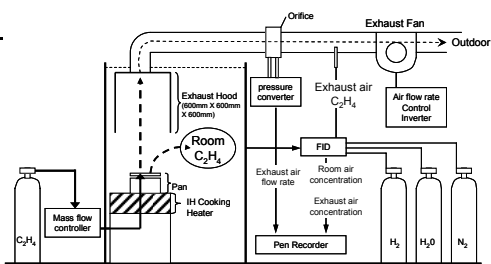

Figure 4. Outline of experiment

## RESULTS

### Updraft above a range

#### (1) Air flow velocity distribution

Fig.5 shows the air flow velocity of the horizontal section of the IH range without a hood from a height of 800mm. Fig.6 shows the air flow velocity distribution of the Y-axis vertical section. When one range is operated, the position of the maximum air flow velocity is directly above the range. When two ranges are operated, the maximum air flow velocity is positioned at the center of the two ranges.

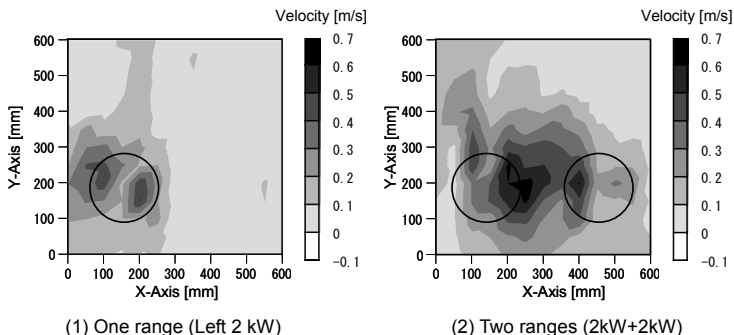

Figure 5. Air flow velocity of updraft (Horizontal section at 800mm, without hood)

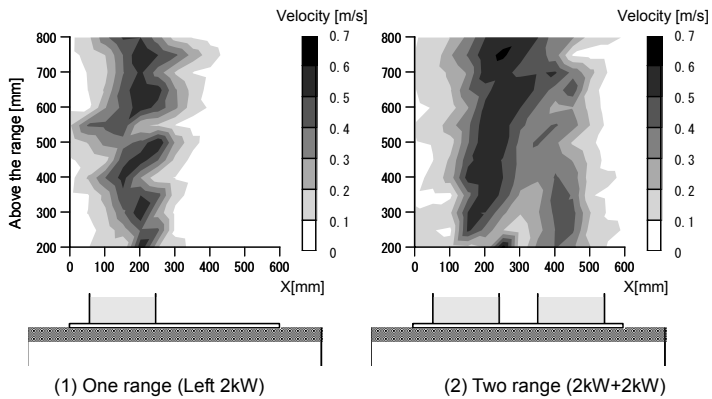

Figure 6. Air flow velocity of updraft (Y-axis vertical section)

## (2) Results of updraft air flow rate

Fig.7 and Table 4 show the updraft air flow rate above the range. Multiplying the air flow velocity of the Z-axis by the cross-section area ( $0.0025\text{m}^2$ ) gives the updraft air flow rate. In the horizontal section of 800mm and 600mm without a range hood, the updraft air flow rate of the left range 2kw and the left range 1kw is nearly equal. In the case where two ranges are operated at 2kW, the updraft air flow rate is about 2 times. In the case of a range without a hood, the updraft air flow rate of the IH range is affected by the number of ranges used more than the power value of the ranges. When the height of the cross-section area from a range is relatively lower, the updraft air flow rate decreases. The updraft air flow rate is about  $255\text{m}^3/\text{h}$  when the height is 800 mm for two ranges, and about  $100\text{m}^3/\text{h}$  for one range. The updraft air flow rate at 600 mm for two ranges and one range is about  $191\text{m}^3/\text{h}$  and about  $86\text{m}^3/\text{h}$  respectively. In the case of 400 mm, the updraft air flow rate is about  $147\text{m}^3/\text{h}$  and  $105\text{m}^3/\text{h}$  respectively.

Table 4. Results of updraft air flow rate

The height of the lower edge of the hood	Range condition	Exhaust air flow rate	Exhaust air flow rate	Exhaust air flow rate	Without hood
		$300\text{m}^3/\text{h}$	$200\text{m}^3/\text{h}$	$100\text{m}^3/\text{h}$	
800mm	Right 2kW + Left 2kW	267	213	196	255
	Left 2kW	196	142	106	99
	Left 1kW	203	144	81	108
600mm	Right 2kW + Left 2kW	229	201	141	191
	Left 2kW	219	144	98	86
	Left 1kW	195	147	81	80
400mm	Right 2kW + Left 2kW	240	189	125	147
	Left 2kW	196	141	86	105
	Left 1kW	180	129	82	

## Results of capture ratio

Results of the capture ratio are shown in Fig. 8, Fig. 9 and Fig.10. The capture ratio of the hood is over 80% when the height of hood is 800 mm and the exhaust air flow rate is  $150\text{m}^3/\text{h}$ . In the case of  $200\text{m}^3/\text{h}$ ,

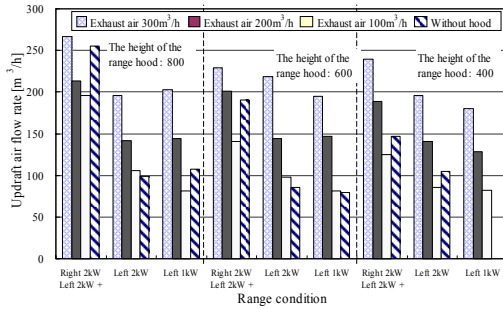

Figure 7. Results of updraft air flow rate

the capture ratio is just over 90%. The capture ratio when the height of the hood is 600 mm is over 90% with an exhaust air flow rate of 150m<sup>3</sup>/h. At 200m<sup>3</sup>/h, the capture ratio is 100%. The capture ratio when the height of the hood is 400 mm is over 80% with an exhaust air flow rate of 100m<sup>3</sup>/h. In the case of 150m<sup>3</sup>/h, the capture ratio is 100%. The power of the range has only a small influence on the capture ratio of the tracer gas. When the number of ranges increases, the capture ratio reduces. The capture ratio improves when the height of the hood is lowered.

### Relationship between required ventilation rate and the number of ranges used [%]

Table 5 shows the updraft air flow rate without a hood and the capture ratio. In this experiment, the capture ratio is just over 90% when exhaust conditions are equal to the updraft air flow rate. As the experimental conditions are without a cross flow above the range, all pollutants are carried by the updraft air flow. Therefore, it is thought that the capture ratio becomes 100% when the exhaust air flow rate is adjusted to the updraft air flow rate. Therefore, the updraft air flow rate can dictate a required ventilation rate. Also, the updraft air flow rate is strongly influenced by the number of the ranges operated. So, the required ventilation rate is strongly related to the number of ranges used. The power value of the range and the surface temperature of the pans, which were always about 100°C, have no influence on the capture ratio. From this result, the capture ratio and the required ventilation rate are strongly related to the number of ranges which are operated.

### The proposal of the required ventilation rate

Fig.11 shows the exhaust air flow rate at capture ratios of 80% and 90%.The exhaust air flow rate is

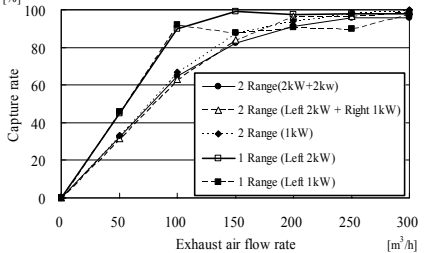

Figure 8. Results of capture ratio (Hood height form the Range is 800mm)

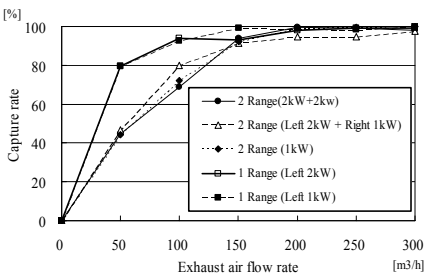

Figure 9. Results of capture ratio (Hood height form the Range is 600mm)

from 130 to 140 m<sup>3</sup>/h at the capture ratio 80% (hood height is 800mm from the range and two ranges are operated). When the height of the hood is 800mm, the hood does not cause disturbance for cooking or putting out fires. In the case of two ranges at the capture ratio 80%, the required ventilation rate is about 150m<sup>3</sup>/h.

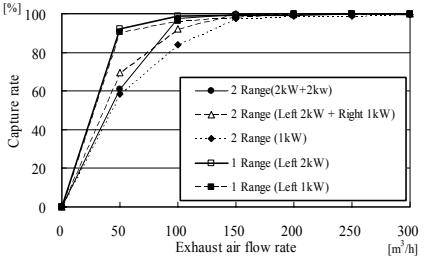

Figure 10. Results of capture ratio (Hood height form the Range is 400mm)

## CONCLUSIONS

- (1) The position of the maximum air flow velocity, when one range is operated, is directly above the range, and when two ranges are operated, is in the center of the two ranges.
- (2) The updraft air flow rate is strongly influenced by the number of ranges operated.
- (3) The capture ratio shows little difference by the electric power value of the range. However, when the number of the ranges increases, the capture ratio would be small.
- (4) When two ranges are operated and the capture ratio is 80%, the required ventilation rate is about 150m<sup>3</sup>/h.

## REFERENCES

1. S. Akabayashi and Y. Kondo, J. Sakaguchi (1998) "Experimental Study on Ventilation Efficiency in Commercial Kitchens", Proceedings of the 6<sup>th</sup> International Conference on Air Distribution in Rooms, Vol. 2, 367-374.

Table 5. Results of updraft air flow rate without range hood and capture ratio

The height of the lower edge of the hood	Range condition	Updraft air flow rate without a hood [m <sup>3</sup> /h]	Capture rate when exhaust air is updraft air flow rate [%]
800mm	Right 2kW + Left 2kW	255	95.9
	Left 2kW	100	90
	Left 1kW	108	91.4
600mm	Right 2kW + Left 2kW	191	98.5
	Left 2kW	86	89.7
	Left 1kW	80	87.3
400mm	Right 2kW + Left 2kW	147	99.6
	Left 2kW	105	98.7

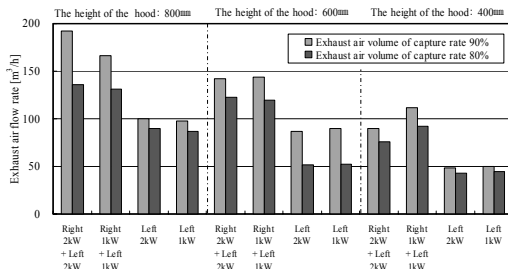

Figure 11. Exhaust air flow rate at the capture ratio 80% and 90%